

Assembly Instructions

Item No.: F7363, F7364

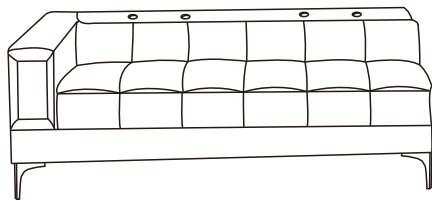

A

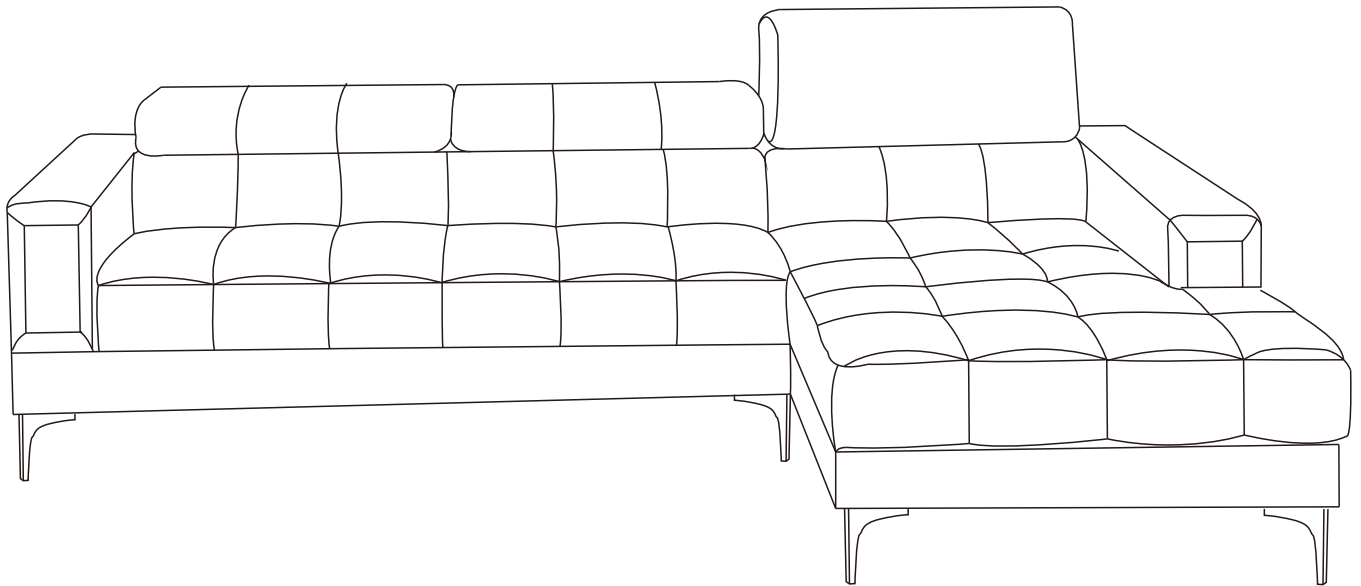
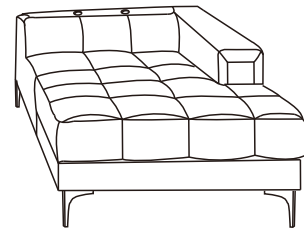

B

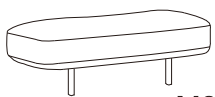

X3

C



X2

D



X8

E



X2

F



X16

G

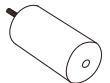

X1

H

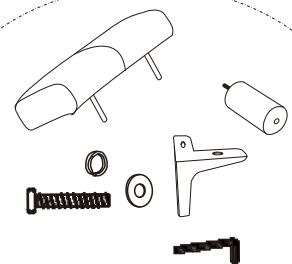
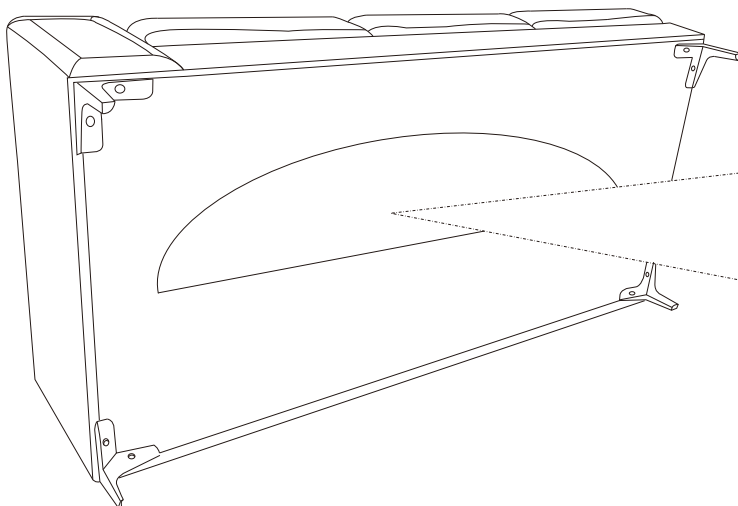

Step 1: Assemble the leg (E) onto the seat frame (A & B) with 2 pcs bolt (G) by Allen wrench (D)

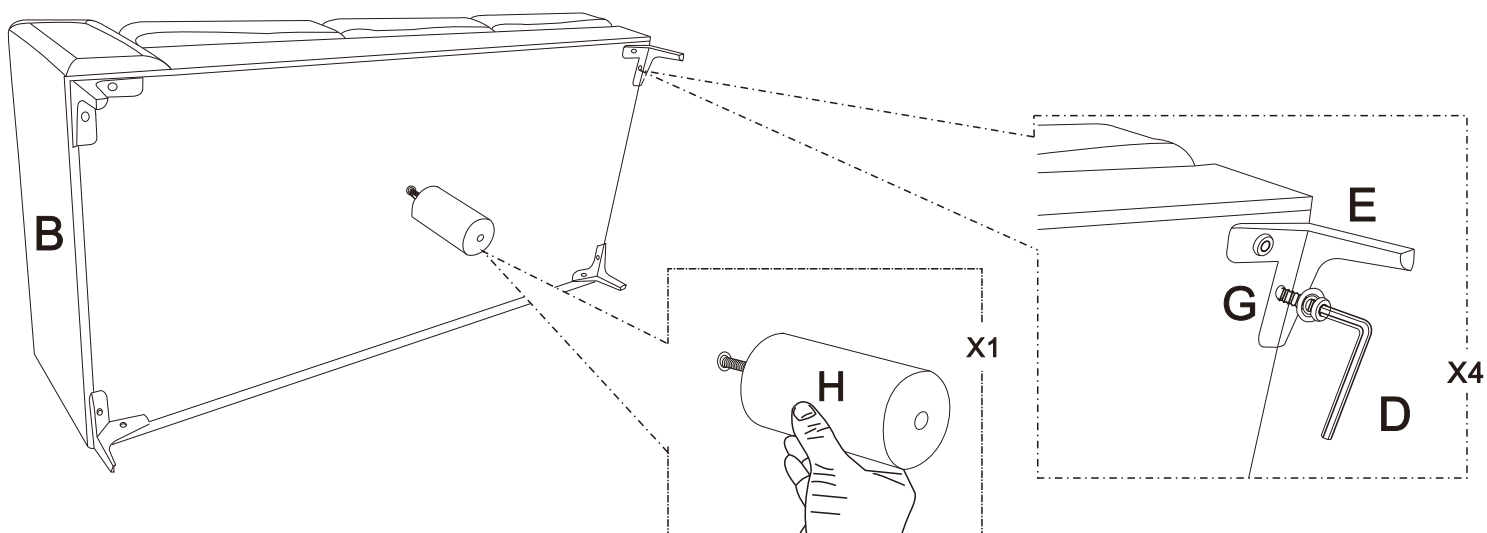

Step 2: Insert headrest (C) into the backrest of sofa (A) & chaise (B).

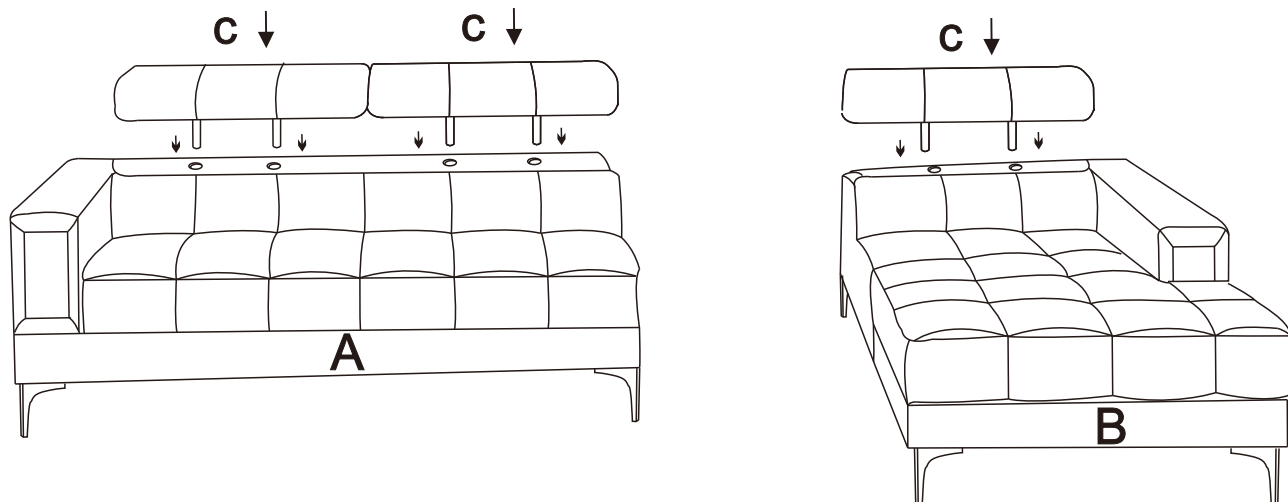

Step 3: Mount the connecting bolt (F) to sofa (A)

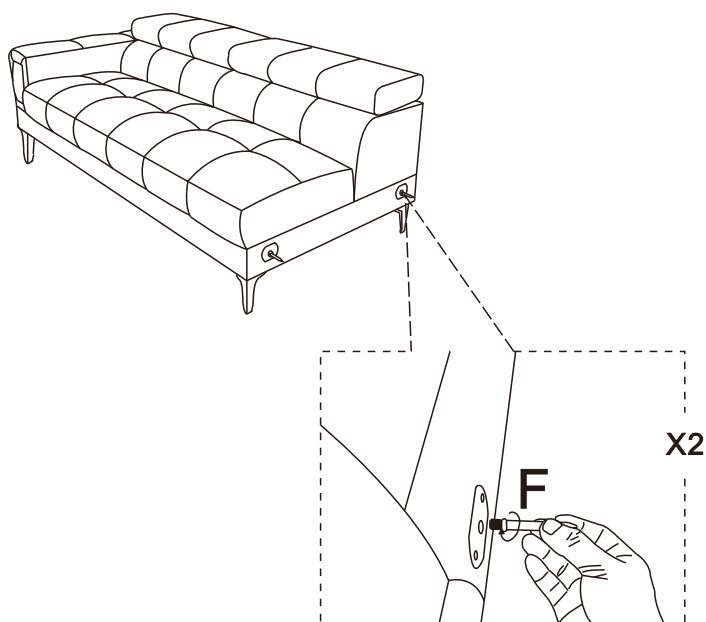

Step 4: Align the connecting bolt (F) with the assembling holes on chaise (B) to tighten sofa (A) and chaise (B) together.

